

# Technical Data

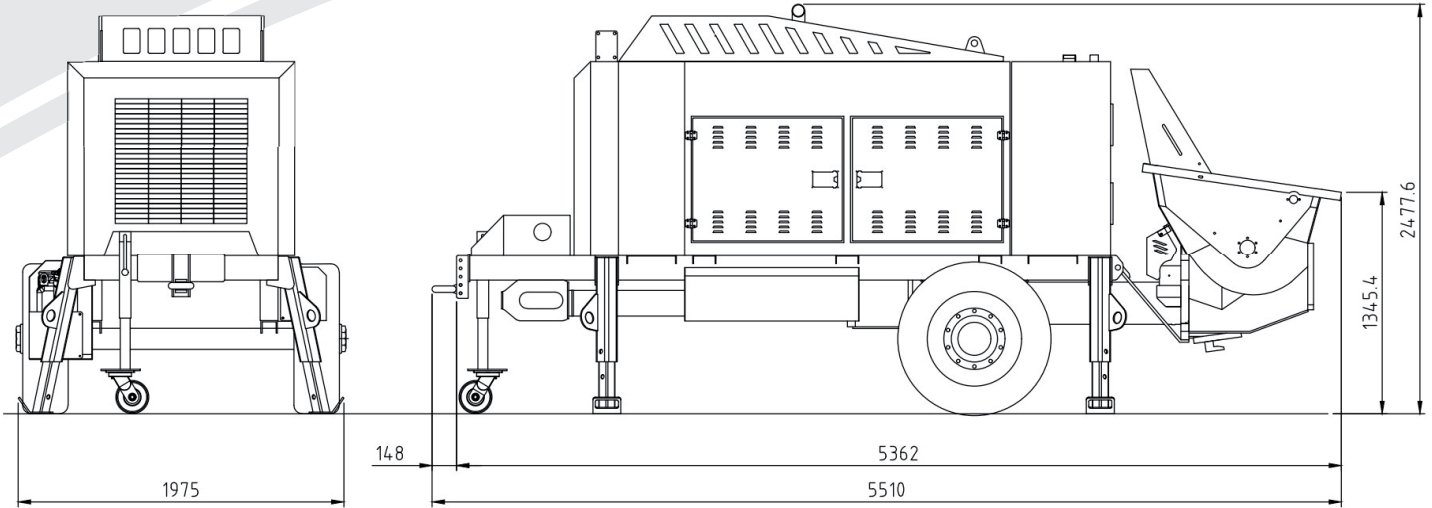

<span style="display: inline-block; width: 10px; height: 10px; background-color: black; margin-right: 5px;"></span> Pump specifications		Wt - 5380kg
Maximum output	Up to 95 [m <sup>3</sup> /h]	
Concrete pressure	Up to 70 [bar]	
Stroke per minute	Up to 32	
Hydraulic Cylinder	Ø130/ Ø80×1400 [mm]	
Concrete cylinder volume dimensions	Ø230×1200 [mm]	
Hopper capacity	0.6 [m <sup>3</sup> ]	
S-tube	Ø200×Ø180 [mm]	
Hydraulic pump	Kawasaki 200S	
Max. aggregate size	40 [mm]	
Engine - EU Stage V	CAT – C7.1 [225kW/301PS]	
Engine rpm	2000 rpm	
Vertical distance	100 [m]	
Horizontal distance	175 [m]	

## ■ Performance diagram

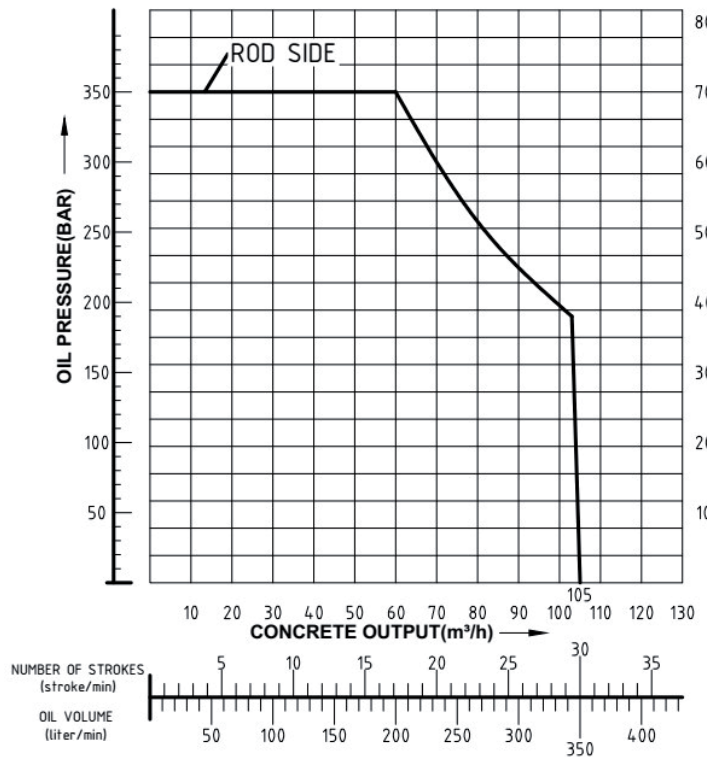

- ⊙ Maximum theoretical values listed
- ⊙ Photos and drawings are for illustrative purpose only
- ⊙ Right to make technical amendments reserved

